



XBOX
LIVE™

THE ULTIMATE
BROADBAND GAMING
EXPERIENCE

To find the latest Xbox *Live* info visit www.xbox.com/live and select your country



LIVE ONLINE ENABLED





ONLINE. GAMES. NOW.



Xbox™ Live™ is...

- The ultimate broadband gaming experience.
- For broadband gaming only. Faster game-play, faster downloads, and no pausing to talk – it's ready to play or be played.
- All about playing great games. On Xbox *Live* gamers can simultaneously play, talk, and build their legend.

All about online. All about the games. All about now.

To find the latest Xbox *Live* info visit www.xbox.com/live and select your country.



ONLY ON XBOX LIVE.

Only Xbox *Live* provides these exclusive features on Xbox *Live* Enabled Games:

Headset for Voice:

The Xbox Voice Communicator delivers the ability to talk hands-free while playing online. Talk tactics, disguise or mute voices.

Exclusive, downloadable

content: Xbox *Live* extends the gameplay experience by allowing exclusive levels, characters, costumes, and rosters to be downloaded to the built-in Xbox hard disk.

Find & play your friends

easily: With the "Friends List", gamers can locate friends across any game, even during gameplay, fast.

Create the perfect game

match: Find the right opponents at your level through the "OptiMatch™" feature.

One ID across all games:

Right out of the box, gamers create their own "Gamertag", allowing them to build their statistics – and their legend – across games.



To find the latest Xbox *Live* info visit www.xbox.com/live and select your country.

GET XBOX *LIVE*. GET CONNECTED.

It's so easy!

- A** Purchase the Xbox *Live* Starter Kit.
- B** Get Xbox *Live* Enabled Games.
Look for the Xbox *Live* Online Enabled logo.

- C** Connect your Xbox to the Xbox *Live* service via broadband Internet access and enter the Ultimate Broadband Gaming Experience*.

* Requires Xbox video game console, compatible broadband connection, Xbox Live starter kit (includes 12 month subscription to Xbox Live, Xbox Voice Communicator headset plus 2 Xbox Live enabled demos) and valid credit card. Xbox *Live* Enabled Games sold separately.

For more information about broadband Internet access, see page 11.

To find the latest Xbox *Live* info visit www.xbox.com/live and select your country.



GET THE XBOX *LIVE* STARTER KIT.

Xbox *Live* Starter Kit includes:



- 12 month subscription to Xbox *Live*.
- Xbox Voice Communicator hands-free headset.
- 2 Xbox *Live* enabled game demos – Whacked!™ and MotoGP Ultimate RacingTechnology™.

See a store associate for more details or other offers. Other Xbox *Live* Enabled Games sold separately.

To find the latest Xbox *Live* info visit www.xbox.com/live and select your country.



Starter Kit

XBOX LIVE ENABLED GAMES

Xbox Live Enabled Games

To find Xbox Live Online Enabled Games, check for this Xbox Live bar.

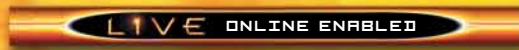

What this bar tells you:
This game can be played online with Xbox Live. You can enter the most exciting gaming experience.

Download New Content

Titles displaying this icon allow you to use the Xbox Live service to download new, exciting content for your games and enhance your gaming experience.



Note: Each player needs their own copy of the game to play online.



Look for these Xbox Live enabled games soon:

- Ghost Recon™ ▪ MechAssault™ ▪ Unreal Championship™
- Star Wars™ The Clone Wars™ ▪ Midnight Club II™
- Capcom® vs. SNK 2™

UP TO **50** MORE IN **2003**

Offline/Online Features

Find the offline and online features supported by a game, check the back of the box for this grid.

<input checked="" type="checkbox"/> Players: 1-4	<input checked="" type="checkbox"/> System Link: 1-8	<input checked="" type="checkbox"/> Online Multiplayer
<input checked="" type="checkbox"/> Memory Unit: 2 Blocks	<input checked="" type="checkbox"/> DVD/USB, VCR, HDD, XBOX	<input checked="" type="checkbox"/> Voice
<input checked="" type="checkbox"/> Custom Soundtracks	<input checked="" type="checkbox"/> Other	<input checked="" type="checkbox"/> Friends
<input checked="" type="checkbox"/> In-game Dolby Digital	<input checked="" type="checkbox"/> Content Download	<input checked="" type="checkbox"/> Scoreboards

X = features supported by this product

Xbox Live Enabled Games can be played offline and online.

To find the latest Xbox Live info visit www.xbox.com/live and select your country.



GET READY TO PLAY. CHOOSE ONE OF THESE THREE METHODS TO CONNECT:

Direct Connect

For cable or DSL modems with an Ethernet port, plug your Xbox directly into the modem.

Do this if:

- You can't wait to start playing on Xbox *Live* and plan to set up a home network later.
- You don't mind moving the Ethernet cable between the PC and the Xbox.
- You don't have a PC connected to the Internet.

Go to page 8

Router connect

Connect your Xbox and PC to the Internet through a router – an excellent option for most Xbox *Live* gamers.

Do this if:

- You want to play Xbox *Live* and surf the Internet at the same time.
- You don't want to move the Ethernet cable from the PC to the Xbox every time you want to play on Xbox *Live*.
- If you already have a home network set up. Just plug your Xbox into the router.

Go to page 9

Internet Connection Sharing (ICS)

Use your PC Windows® ICS to connect your Xbox to the Internet.

Do this if:

- Your broadband Internet service supports USB modems only.
- You prefer buying an internal Ethernet network card or an external Ethernet/USB device for your PC instead of buying and installing a router.

Go to page 10

To find the latest Xbox *Live* info visit www.xbox.com/live and select your country.



DIRECT CONNECT

Plug your Xbox directly into your broadband modem*.

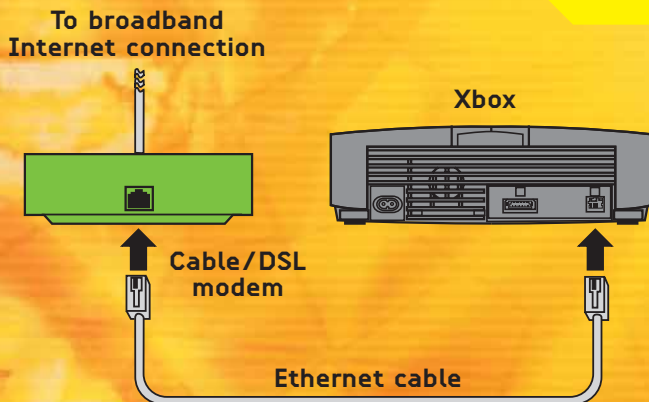

* Not suitable for USB modems

** More information about connectivity is available at www.xbox.com/live and select your country.

What you need:

- Broadband modem with Ethernet out.
- Ethernet cable – either a straight or crossover Ethernet cable, depending on the type of modem used**.

Things to consider:

- This is the quickest way to get connected to Xbox Live.
- It's a great solution if you want to dedicate your broadband connection to Xbox Live.
- The PC and Xbox can't use the Internet at the same time. You will need to move the Ethernet cable from the PC to the Xbox when you want to play on Xbox Live.



INTERNET CONNECTION SHARING (ICS)

Use ICS to connect your Xbox to the Internet.

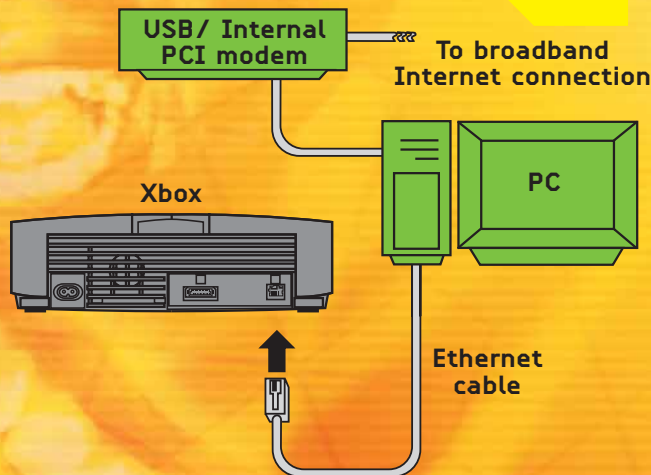

What you need:

- Unused Ethernet port on your PC.
- Ethernet crossover cable.

Things to consider:

- The PC must be turned on when you use Xbox *Live*.
- The internal or external Ethernet card must be installed unless your PC already has an Ethernet card.
- ICS is a feature of Windows® Millennium Edition (ME), Windows® 2000, Windows® 98SE and Windows® XP*.

*For details about ICS configuration, visit www.xbox.com/live and select your country.

To find the latest Xbox *Live* info visit www.xbox.com/live and select your country.



XBOX COMPATIBLE PROGRAM



Xbox *Live* is designed to work with most broadband internet services and home routers*. To make it even easier to have a great experience and find the right provider or manufacturer, we've created the Xbox Compatible program.

Look for the Xbox Compatible logo on...

Broadband Internet plans offered by:

Cable/DSL Internet Access Providers.

- A broadband Internet service that displays the Xbox Compatible logo can be connected to an Xbox, and the service will provide performance appropriate for Xbox *Live*. Be advised that, as with any Internet service, temporary service interruptions may occur.
- If a broadband Internet service does not display the Xbox Compatible logo, contact the service provider for more information about the suitability of their service for use with Xbox *Live*.
- For the most up-to-date list of Xbox Compatible service providers, visit www.xbox.com/live and select your country.

Broadband Ethernet routers offered by:

Cable/DSL Ethernet Router Manufacturers.

- A home router that displays the Xbox Compatible logo can be connected to an Xbox and will work with Xbox *Live*.
- If a home router does not display the Xbox Compatible logo, contact the manufacturer for more information about the suitability of their product for use with Xbox *Live*.
- For the most up-to-date list of Xbox-compatible routers, visit www.xbox.com/live and select your country.

*While most Cable or DSL broadband Internet services will work with Xbox *Live*, some may not - check with your service provider.



FAQ

Q A

What's required to get connected to Xbox Live?

- An Xbox console, an Xbox Live Enabled Game, broadband Internet access (cable or DSL), an Ethernet modem or other device to connect to your Xbox, a subscription to Xbox Live and a valid credit card.

What if I don't have broadband Internet access?

- You must have broadband Internet access (cable or DSL). That's number one.
- If you don't have it, get it. Visit www.xbox.com/live, and select your country, for more information.

Can I play the Xbox games I already own on Xbox Live?

- Only if they are Xbox Live Enabled Games. All Xbox Live games will have the Xbox Live Online Enabled bar on the front of the package (see the bar on page 6). If a game doesn't have the bar, it's not enabled for Xbox Live.

Can I use the Xbox System Link Cable as an Ethernet cable?

- A system link cable is a type of Ethernet cable. Depending on your modem, you might be able to use it. See www.xbox.com/live, and select your country, for more information.

What if I want to take my Xbox Live profiles to my friend's house?

- Just save the game to your memory unit* and head on over.

Do I need Xbox Live in order to play Xbox Live Online Enabled Games?

- No, you can enjoy Xbox Live Enabled Games offline as well as online. You might even want to do a little training offline before you begin conquering your online foes...

Why do I need a credit card?

- This is the most efficient way to secure Gamertag authorization.

I still want more information. Where can I get it?

- You can find all the answers you're looking for at www.xbox.com/live, and select your country.

* memory unit sold separately





Information in this document, including URL and other Internet Web site references, is subject to change without notice. Complying with all applicable copyright laws is the responsibility of the user. Microsoft may have patents, patent applications, trademarks, copyrights, or other intellectual property rights covering subject matter in this document. Online game play and/or downloadable content not available for all games. Specific game features are called out on the game packaging. © 2003 Microsoft Corporation. All rights reserved. Microsoft, Xbox, the Xbox logos, and Xbox Live are either registered trademarks or trademarks of Microsoft Corporation in the US and/or other countries. The names of actual companies and products mentioned herein may be trademarks of their respective owners. Xbox Live subscription sold separately.

Important! Before using this product, read the Xbox Instruction Manual for important safety information and health warnings.
Please retain both the Xbox Instruction Manual and these instructions for future reference.

REVERSE PRINT OF ALL PAGES

